

- 20 gauge 316 stainless steel construction
- Bell inlet and flanged outlet duct connections
- Orifice ring flow sensor
- 90° damper with solid stainless steel shaft with position indicator
- No maintenance Teflon bearings
- Stainless steel unit has stainless steel damper blade and NO seal
- Continuous seam weld
- No Insulation options

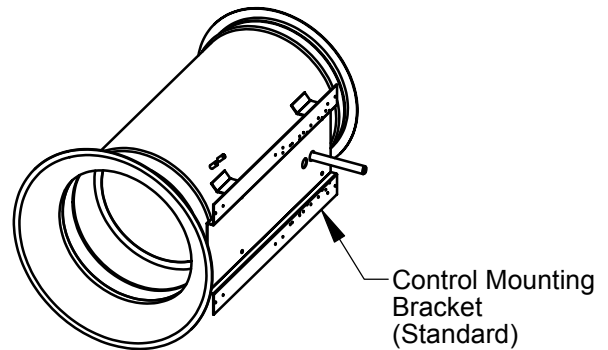

Size	Max CFM	L	A	B
4	260	17	13	5 1/4
5	410	17	13	5 1/4
6	590	18 1/2	14 1/2	6 3/4
7	800	18 1/2	14 1/2	6 3/4
8	1045	18 1/2	14 1/2	6 3/4
10	1635	22	15 3/4	6 3/4
12	2350	23	15 3/4	6 3/4
14	3200	25 1/2	17	6 3/4
16	4200	27 1/2	18	6 3/4

Control Enclosure (Optional)

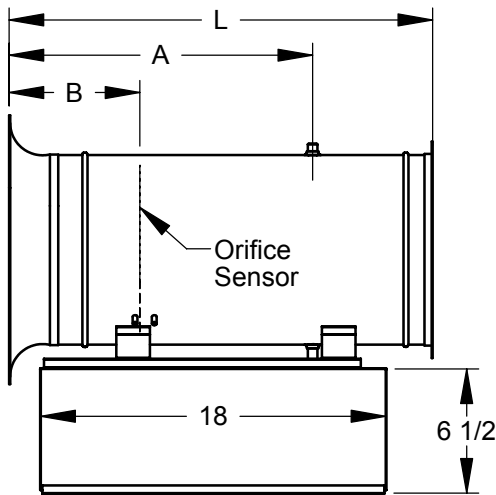
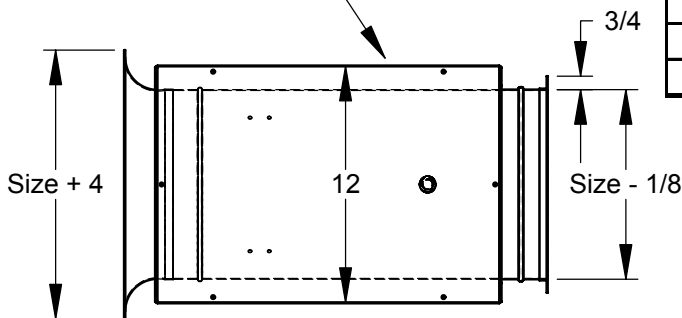

### Options

316 Stainless Steel

### Control Options

NEMA 1 Control Enclosure  
 Dust Tight Seal on Control Enclosure  
 Controls Disconnect  
 24V Transformer  
 Primary Voltage  
 24V 120V 208V 240V 277V

Dimensions in inches

Job: \_\_\_\_\_  
 Location: \_\_\_\_\_  
 Architect: \_\_\_\_\_  
 Engineer: \_\_\_\_\_  
 Contractor: \_\_\_\_\_

Submitted By: \_\_\_\_\_

SD-7109

Rev: A (02/05)

**RRV**

**Exhaust Terminal Unit  
 Bell / Flange Connections  
 Orifice Sensor**