

- 20 gauge galvanized steel construction (optional 316 stainless steel)
- Slip inlet and outlet duct connections accept industry standard sizes
- Orifice ring flow sensor (requires 2 ½ equivalent duct diameters of straight duct upstream of the sensor)
- 90° damper with solid stainless steel shaft with position indicator
- No maintenance Teflon bearings
- Galvanized unit has galvanized damper blade and seal
- Stainless steel unit has stainless steel damper blade and NO seal
- Continuous seam weld
- No Insulation options

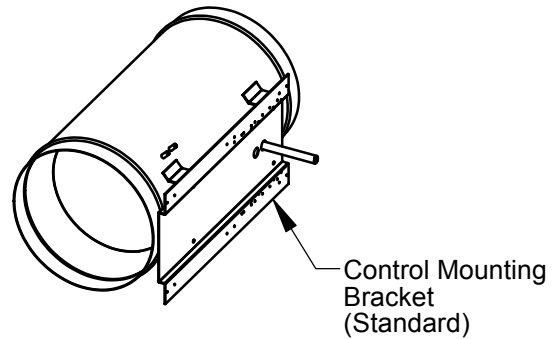
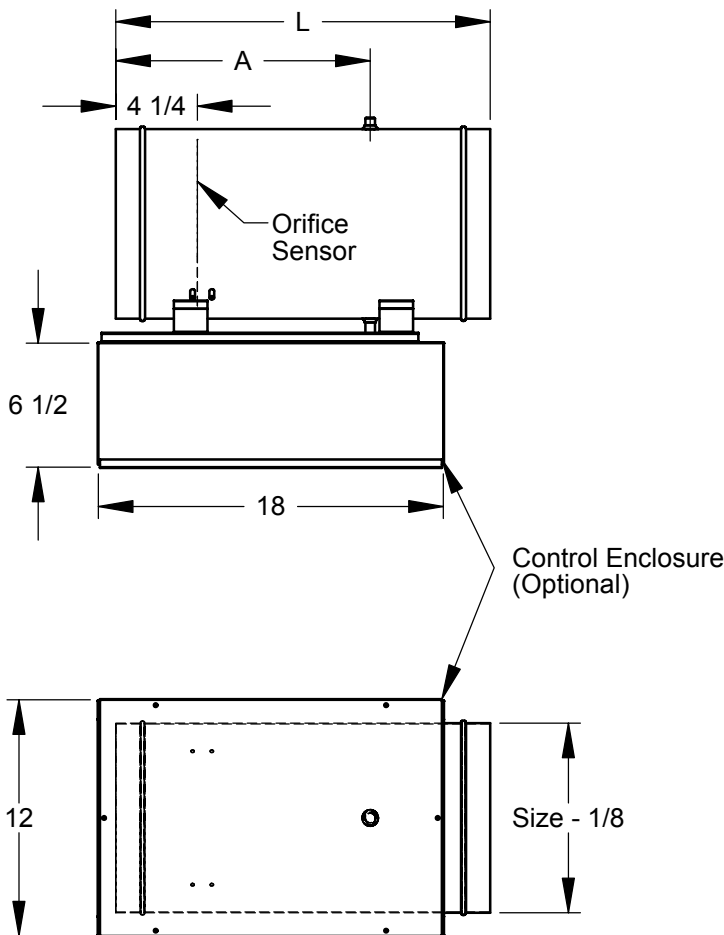

Size	Max CFM	L	A
4	260	16	12
5	410	16	12
6	590	16	12
7	800	16	12
8	1045	16	12
10	1635	19 1/2	13 1/4
12	2350	20 1/2	13 1/4
14	3200	23	14.5
16	4200	25	15.5

Options

Galvanized Steel
316 Stainless Steel

Control Options

NEMA 1 Control Enclosure
Dust Tight Seal on Control Enclosure
Controls Disconnect
24V Transformer
Primary Voltage
24V 120V 208V 240V 277V

Dimensions in inches

Job: _____
Location: _____
Architect: _____
Engineer: _____
Contractor: _____

Submitted By: _____

SD-7106

Rev: A (02/05)

RRV

**Exhaust Terminal Unit
Slip / Slip Connections
Orifice Sensor**